



PIPE CLAMPS

STANDARD PIPE CLAMP P520 & P520Z

Surface Finish: P 520: Plain, Black; P520Z: Electro-Plated Zinc

Industrial pipe hanger for hot or cold service where no insulation is required

Normally used in conjunction with a #40 Eye Rod or a #35 Forged Steel Eye Nut

Complies with Manufacturers' Standardization (MSS) SP-58 and SP-69 (Type 4)

Material: Low carbon steel, available in stainless steel to order, specify 304, 316

Ordering: Specify pipe size and figure number

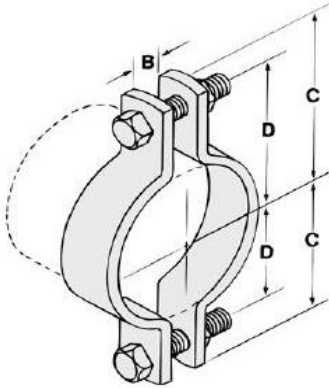

Pipe Size (inch)	B (inch)	C (inch)	D (inch)	Material Size (inch)	Bolt Size (inch)	Max. Rec. Load/lbs		Wt. Each (in lbs)
						650 F Degree	750 F Degree	
1/2	3/8	1-9/16	1-1/16	11 ga. X 1	3/8	500	445	0.31
3/4	3/8	1-3/4	1-1/4	11 ga. X 1	3/8	500	445	0.35
1	3/8	1-7/8	1-3/8	11 ga. X 1	3/8	500	445	0.39
1-1/4	3/8	2-1/8	1-5/8	11 ga. X 1	3/8	500	445	0.40
1-1/2	3/8	2-1/4	1-3/4	11 ga. X 1	3/8	800	715	0.45
2	1/2	2-5/8	2-1/8	3 ga X 1	1/2	1040	930	1.23
2-1/2	5/8	3-1/8	2-5/8	3 ga X 1	1/2	1040	930	1.33
3	5/8	3-1/2	3	3 ga X 1	1/2	1040	930	1.53
3-1/2	5/8	3-11/16	3-3/16	3 ga X 1	1/2	1040	930	1.68
4	3/4	4-1/16	3-7/16	3 ga X 1	5/8	1040	930	1.86
5	3/4	4-15/16	4-5/16	3 ga X 1	5/8	1040	930	2.13
6	7/8	5-3/4	4-7/8	3/8 X 1-1/2	3/4	1615	1440	5.06
8	1	7	6	3/8 X 1-1/2	3/4	1615	1440	6.08
10	1	8-9/16	7-9/16	1/2 X 2	7/8	2490	2220	12.81
12	1	9-7/8	8-7/8	1/2 X 2	7/8	2490	2220	13.08
14	1-1/8	11-5/16	9-15/16	1/2 X 2	7/8	2490	2220	16.70
16	1-1/8	12-5/8	10-7/8	1/2 X 2-1/2	7/8	2490	2220	23.19
18	1-1/4	13-3/8	9-5/8	5/8 X 2-1/2	1	3060	2730	33.12
20	1-3/8	14-5/16	12-9/16	5/8 X 2-1/2	1-1/8	3060	2730	38.66
24	1-5/8	17-1/4	15-1/2	5/8 X 3	1-1/4	3060	2730	52.27
30	2	20-7/8	18-5/8	5/8 X 4	1-1/4	4000	3520	105.13



PIPE CLAMPS

HEAVY DUTY PIPE CLAMP P522 & P522Z

Surface Finish: P 522: Plain, Black; P522Z: Electro-Plated Zinc

Industrial pipe hanger for hot or cold service where no insulation is required

Normally used in conjunction with a #40 Eye Rod or a #35 Forged Steel Eye Nut

Complies with Manufacturers' Standardization (MSS) SP-58 and SP-69 (Type 4)

Material: Low carbon steel, available in stainless steel to order, specify 304, 316

Ordering: Specify pipe size and figure number

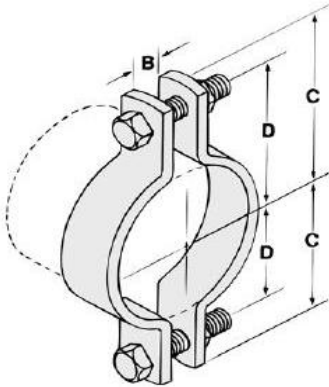

Pipe Size (inch)	B (inch)	C (inch)	D (inch)	Material Size (inch)	Bolt Size (inch)	Max. Rec. Load/lbs		Wt. Each (in lbs)
						650 F Degree	750 F Degree	
3	1	4-1/8	3	3/8 X 2	3/4	3370	3005	4.96
3-1/2	1	4-3/8	3-1/4	3/8 X 2	3/4	3370	3005	5.36
4	1	4-15/16	3-11/16	3/8 X 2	7/8	3515	31353	5.74
5	1	5-9/16	4-5/16	3/8 X 2	7/8	3515	3135	7.13
6	1-1/8	6-11/16	5-3/16	1/2 X 2-1/2	1	4865	4340	13.48
8	1-1/8	7-3/4	6-1/4	1/2 X 2-1/2	1	4865	4340	15.78
10	1-1/4	9-1/2	7-7/8	5/8 X 2-1/2	1-1/4	6010	5360	24.20
12	1-5/8	11-5/8	9-1/2	3/4 X 3	1-1/2	8675	7740	41.54
14	1-5/8	12-1/4	10-1/8	3/4 X 3-1/2	1-1/2	9120	8135	53.25
16	1-5/8	13-5/16	11-3/16	3/4 X 3-1/2	1-1/2	9120	8135	56.35
18	1-5/8	14-5/16	12-3-16	3/4 X 4	1-1/2	9150	8160	70.12
20	1-5/8	15-7/16	13-5-16	3/4 X 4	1-1/2	9150	8160	74.68
24	1-3/4	17-3/4	15-3/8	3/4 X 6	1-1/2	9200	8205	126.29